



[Product Description]

Our new 1140L single axle highway tow pressure washer bowser features our tough, rotationally moulded polyethylene tank mounted on a galvanised tubular steel chassis. The large mounting plate accommodates the pressure washer unit and lance holder.

This product is ideally suited for use in the following applications:

- ▶ Construction
- ▶ Industrial
- ▶ Council & municipal
- ▶ Agriculture



Tough galvanised chassis with handbrake



Rear bumper with road legal lighting system

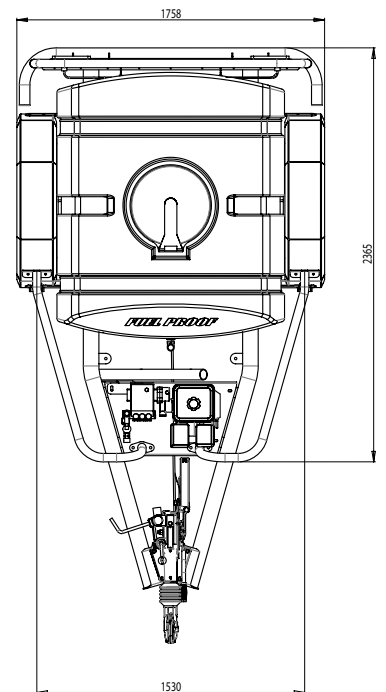

[Specification of unit shown]

- ▶ 1140 litre (250 gallon capacity)
- ▶ Rotationally moulded polyethylene tank
- ▶ Galvanised tubular steel chassis
- ▶ Recoil start 6.5hp Honda petrol engined pressure washer unit - 14 lpm @ 150 bar
- ▶ 10 metres of hose
- ▶ Single high-speed axle
- ▶ Overrun brakes, hitch and damper
- ▶ Baffled tank for improved stability
- ▶ Secure lockable lid
- ▶ 2" bottom outlet for easy cleaning of unit
- ▶ 1" outlet front and rear
- ▶ 380mm diameter manway into top of tank
- ▶ Lance holder
- ▶ Lighting system complies with highway regulations

[Technical Information]

Length:	3400mm
Width:	1758mm
Height:	1346mm
Capacity:	1140 litres (250 gallons)
Weight (empty):	451kg
Weight (full):	1590kg

