

1140L Highway Tow Pressure Washer Bowser Twin Axle 11 HP Petrol 15 lpm @ 200 bar



[Product Description]

Our new 1140L highway tow pressure washer bowser features our tough, rotationally moulded polyethylene tank mounted on a galvanised tubular steel chassis. The large mounting plate accommodates the pressure washer unit and hose reel, which are protected by the tubular steel side bars. Mounted above the mudguards are large capacity stainless steel detergent and anti-freeze tanks, each with a liquid level gauge at the rear.

This product is ideally suited for use in the following applications:

- ▶ Construction
- ▶ Industrial
- ▶ Council & municipal
- ▶ Agriculture



Pressure washer unit and hose reel



Rear bumper with road legal lighting system

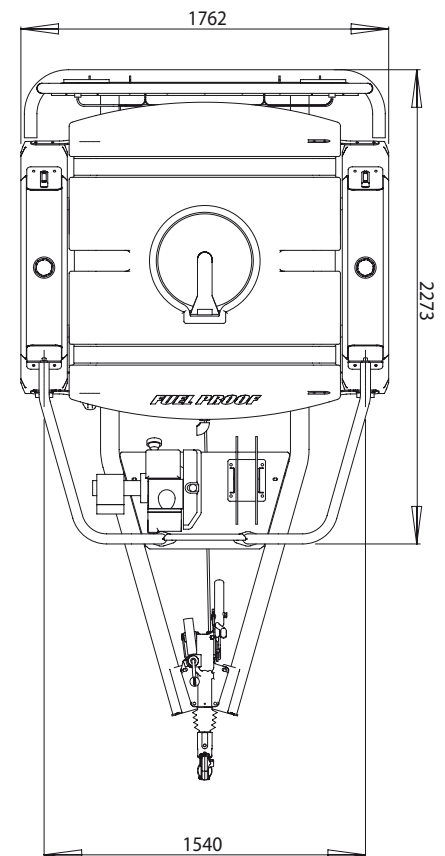

[Specification of unit shown]

- ▶ 1140 litre (250 gallon capacity)
- ▶ Rotationally moulded polyethylene tank
- ▶ Galvanised tubular steel chassis
- ▶ Large capacity stainless steel detergent & anti-freeze tanks with level gauge (30 litre capacity)
- ▶ Recoil start 11hp Honda petrol engine pressure washer unit - 15 lpm @ 200 bar
- ▶ Stainless steel hose reel with 10 metres of hose
- ▶ Twin high-speed axle
- ▶ Overrun brakes, hitch and damper
- ▶ Baffled tank for improved stability
- ▶ Secure lockable lid
- ▶ 2" bottom outlet for easy cleaning of unit
- ▶ 1" outlet front and rear
- ▶ 380mm diameter manway into top of tank
- ▶ Lance holder
- ▶ Lighting system complies with highway regulations

[Technical Information]

Length:	3404mm
Width:	1762mm
Height:	1236mm
Capacity:	1140 litres (250 gallons)
Weight (empty):	600kg
Weight (full):	1740kg

